



**Part no.: 50117254**  
**BTU 200M-D14**  
**Mounting system**



Figure can vary

## Contents

- Technical data
- Dimensioned drawings
- Accessories



Part no.: 50117254 – BTU 200M-D14 – Mounting system

## Technical data

<b>Basic data</b>	
Contains	2x position washers 2x M3 x 18 screw
Suitable for	5 series sensors 3B series sensors 28 series sensors 55 series sensors 25B series sensors 18 series sensors
<b>Mechanical data</b>	
Standard designation, metal mounting device	Aluminum Steel, galvanized
Design of mounting device	Mounting system
Type of fastening, at system	For 14 mm rod Sheet-metal mounting
Type of fastening, at device	Screw type
Type of mounting device	Adjustable Clampable Turning, 360°
Mounting device material	Metal
<b>Classification</b>	
eCl@ss 8.0	27279202
eCl@ss 9.0	27273701

## Dimensioned drawings

All dimensions in millimeters

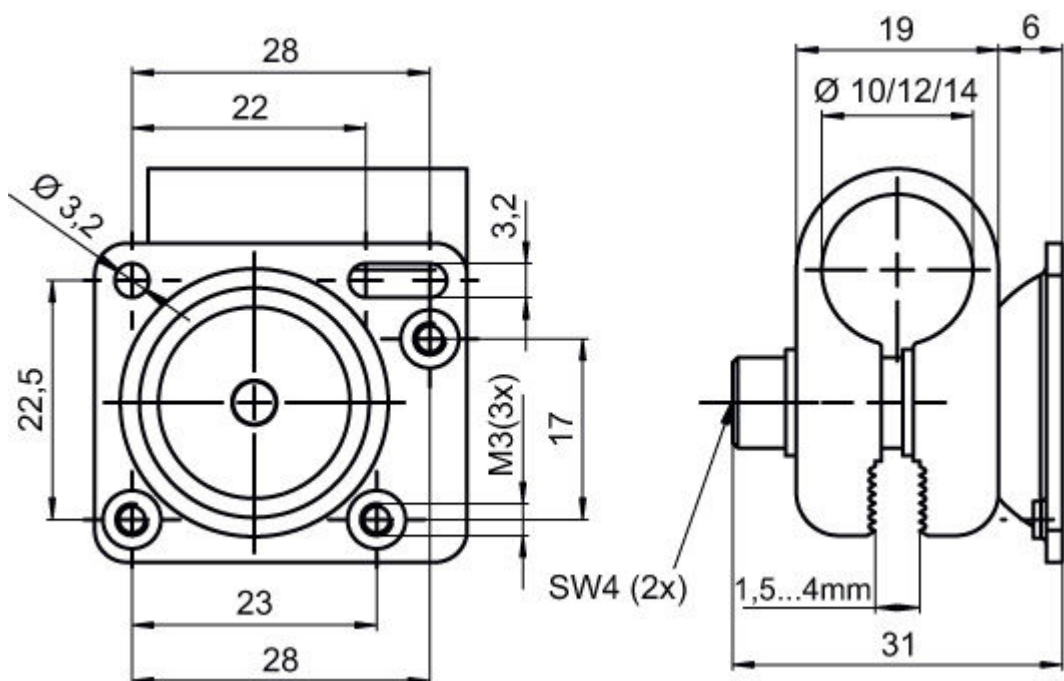

Part no.: 50117254 – BTU 200M-D14 – Mounting system

## Accessories

### Micro-triad-type reflectors

	Part no.	Designation	Article	Description
	50040895	MTKS 20x20	Reflector	Design: Rectangular Reflective surface: 20 mm x 20 mm Material: Plastic Base material: Plastic Chemical designation of the material: PMMA8N Fastening: Through-hole mounting, Adhesive